

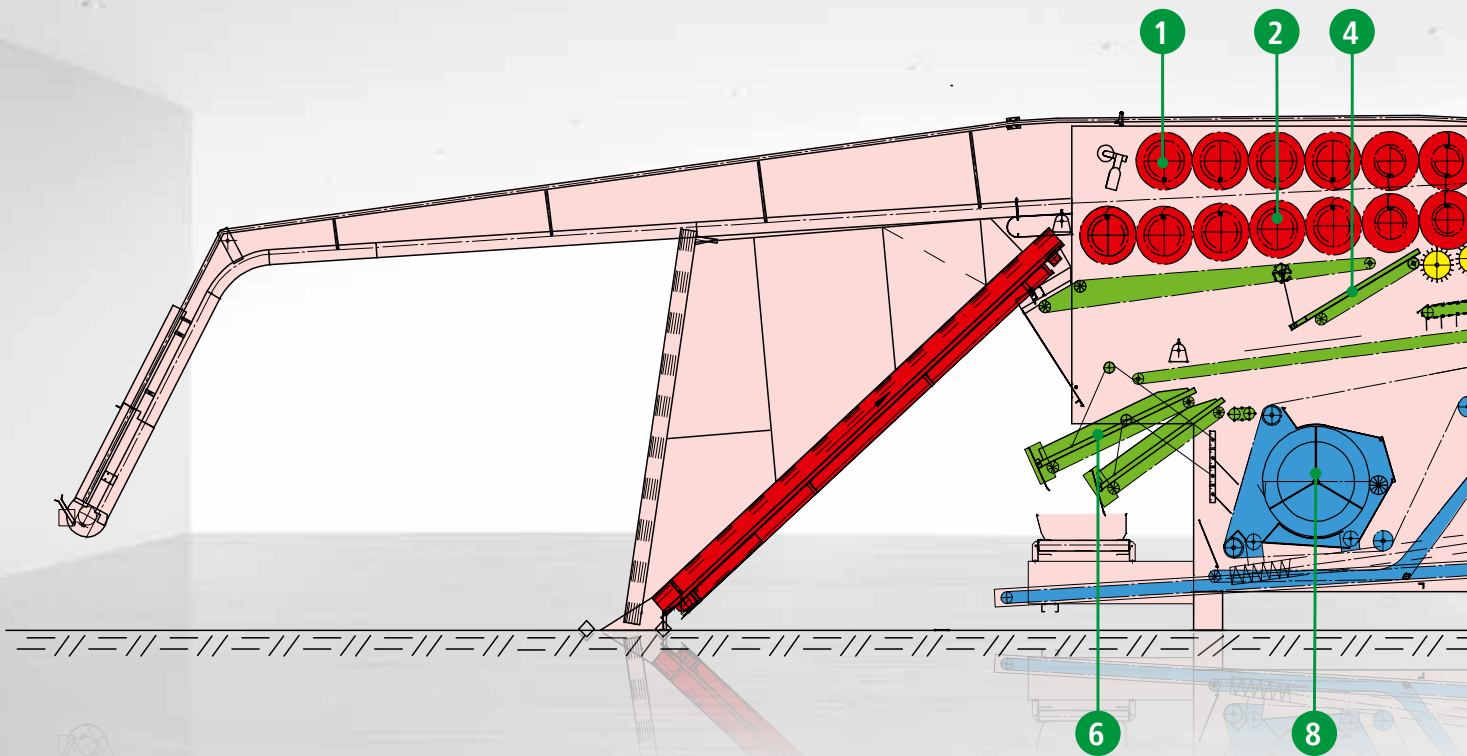

WHE 513 HIGH-PERFORMANCE PICKING MACHINE





WHE HOP-PICKING MACHINE

The WHE hop-picking machine is the most compact picking machine in the WOLF program, featuring highest efficiency and an excellent picking result: Highest cone quality, cleanly harvested bines without any damages.

The electronic control system holds a great potential for optimizing machines and processes. Indispensable in automotive technology, regulation technology has meanwhile conquered its firm place also in agricultural technology.

We have consistently followed this way when developing the WHE 513.

Almost all motors of the machine now have a stepless regulation by frequency converters. More motors have been installed in order to improve the possibilities of fine adjustment. This enables even better picking results in highest purity.

Up to 30% of electric energy can be saved by frequency-controlled motors. Once the motors were operated always in full load; by stepless control by frequency converters, they can now run in partial load most of the time, providing a power-saving effect as well as a longer durability of the motors and a quieter operation of the picking machine.

ADVANTAGES

- ▶ Optimal speed control for best performance and minimum wear
- ▶ Very smooth running by speed adjustment
- ▶ Energy saving by minimum power request
- ▶ Time saving and easier handling
- ▶ Clean picking result and higher capacity by coarse collection
- ▶ Less alpha loss by pre-collection and individual wind regulation

PICKER

1 Approved Picking Drums

The 13 picking drums provide a solid capacity reserve. Even at a slower speed, you will achieve sensational results.

2 Picking Fingers

Picking fingers with springs in the last two pairs of picking drums enable a careful intervention into the whole bine depth. The cones are „wiped off“ carefully.

The fingers of the subsequent picker (4 mm thick) support the self-cleaning effect. (Different spring sizes available)

3 New Sickle Cutter

The quiet and wear-free sickle cutter is processing the cleanly picked bines.

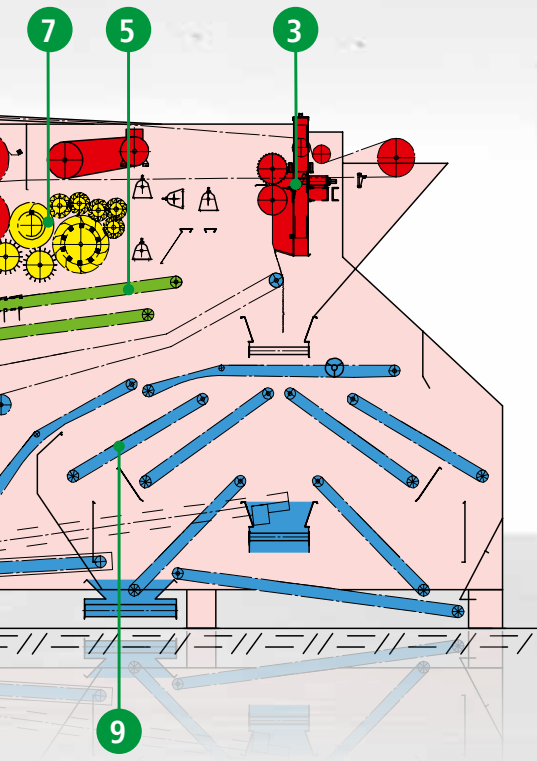

Touch Display

By a clear Touch Display which is easy to handle, you can centrally control the whole WHE 513. The mobile panel serves for adjustment on site, so that you can immediately check the result.



PRE-COLLECTION

STARPICKER[®] SZ

CLEANING

4 Subsequent Picker Bypass

Up to 70% of the crops are led to double pre-collection before the subsequent picker. Picked cones are harvested already before the subsequent picker, thus relieving the subsequent picker and providing a capacity increase, a smoother running and a higher picking quality.

5 Folding Belt

Coarse stems, bunches and large leaves are conveyed by the folding belt directly to the waste.

6 Double Pre-Collection

By dividing the quantities, more space for rolling down the cones is provided on the belts. bypasses.

7 STARPICKER[®] SZ

The **STARPICKER[®] SZ** is the compact subsequent picker unit by WOLF.

Different picking drums, optimized in speed and design, are separating the cones from the remaining material.

The **STARPICKER[®] SZ** is working maintenance-free during the harvest. It is nearly impossible for bines winding or waste material collecting in the picking drums.

This self-cleaning effect has been reached by a special cleaning unit. The rake belt below is filtering out coarse waste.

8 Cleaning Fan

The stepless control system of the fan speed makes the cleaning fan especially quiet. Any alpha deposits are minimized. Frequency-controlled motors are saving a lot of energy.

9 Rubber Belt Cleaning

The approved belt cleaning system has remained unchanged from the previous version. As usual, the cleaning can be adjusted quite uncomplicated. Here, the last cone is separated from green hops.



AGRICULTURAL ENGINEERING

WOLF Anlagen-Technik GmbH & Co. KG
Münchener Str. 54 - 85290 Geisenfeld

Phone +49 (0)8452 99-0
Fax +49 (0)8452 99-250

Mail info.lt@wolf-geisenfeld.de
Web www.wolf-geisenfeld.de